



STUDENT NAME: _____

2021 VISUAL COMMUNICATION DESIGN 3&4

Written examination

Reading time: 15 minutes

Writing time: 1 hour 30 minutes

QUESTION AND ANSWER BOOK

Structure of book

<i>Number of questions</i>	<i>Number of questions to be answered</i>	<i>Number of marks</i>
10	10	60

- Students are permitted to bring into the examination room: pens, lead and coloured pencils, fineliners, highlighters, erasers, sharpeners, rulers, set squares, protractors, compasses, and circle and ellipse templates.
- Students are NOT permitted to bring into the examination room: markers, tee-squares and boards, texture boards, blank sheets of paper and/or correction fluid/tape.
- No calculator is allowed in this examination.

Materials supplied

- Question and answer book of 16 pages
- Resource book of 10 pages

Instructions

- Write your **student number** in the space provided above on this page.
- All written responses must be in English.

At the end of the examination

- You may keep the resource book

Students are NOT permitted to bring mobile phones and/or any other unauthorised electronic devices into the examination room.

Question 4 (9 marks)

Refer to the resource book for larger colour versions of the images that are related to Question 3.

**Figure 7**

Figure 6 shows an advertisement design for an organic beauty serum.

- a. Identify the design field of Figure 7

1 mark

- b. With reference to a target audience, describe how two design elements have been used effectively in the design.

3 marks

c. Identify a suitable **context** for Figure 7 and explain why you chose it.

2 marks

d. Name one **specialist** that may have worked with the designer. Explain the role of the specialist professional and how they may have worked together with the designer. Use evidence from Figure 7 in your response.

3 marks

SAMPLE

Question 8 (8 marks)

Figure 10 is a line drawing of a hair dryer that you are required to render in colour.

The arrow indicates the direction of the light. You may refer to the images below of relevant surfaces materials to assist you. (Larger images are available in the resource booklet).

Your response must:

- use the **light source as indicated by the arrow** to enhance the form
- include cast **shadows** on the hairdryer
- use **tone** and **colour** to render the sections of the hairdryer to indicate the following surface materials: (see labelled diagram below to assist you)
 - shiny silver plastic for the front half
 - coloured plastic for the back and handle
 - Smooth rubber for the inner grip and chord connector
 - Textured rubber for the button

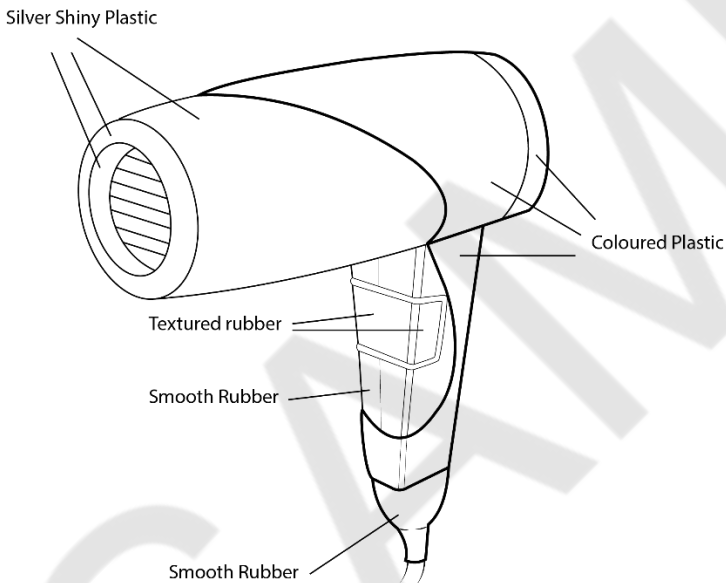

Figure 11

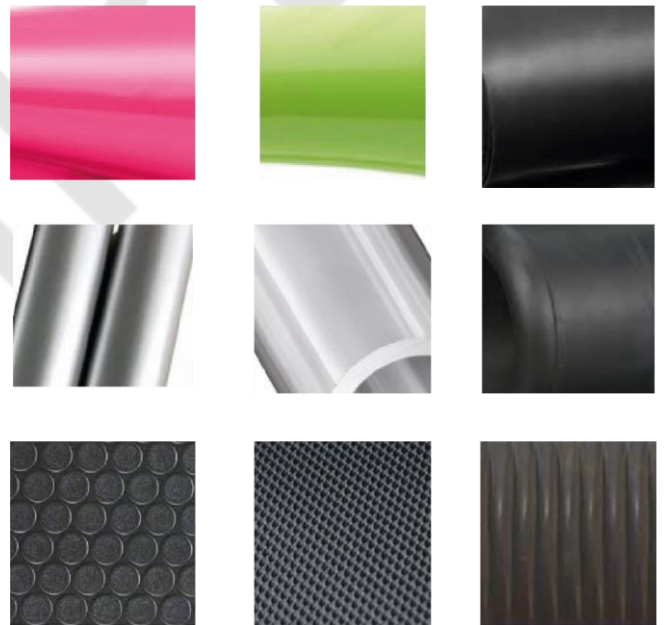

Figure 12